



LENNOX

R290 LenTherma Series



Mono 4-16kW

Product Lineup

	Capacity(kW)	4	6	8	10	12	14	16
Mono	220-240V-1N-50Hz	•	•	•	•	•	•	•
	380-415V-3N-50Hz					•	•	•



Environment friendly

- R290 Natural Refrigerant
- GWP=3
- ODP=0



Wider temperature range

- Min OAT=-25°C
- Max LWT=75°C



User friendly controller

- Color screen
- Scenic and intuitive interface



Comfort and health

- Silence mode
- Disinfection
- Double zone control



High efficiency

- Space heating up to A+++ (W35)
- Higher capacity output even at a low temperature



High reliability

- Hermetic electric control box
- Explosion-proof design
- Vertical placed key component

Abbreviation

GWP: Global Warming Potential
ODP: Ozone Depletion Potential

OAT: Outdoor Ambient Temperature
LWT: Leaving Water Temperature

Compatible with different kinds of terminals



Fan coil unit



Radiator



Water tank

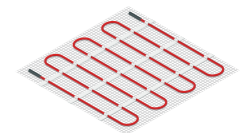

Floor heating loop

Wide operation range

Ambient temperature range

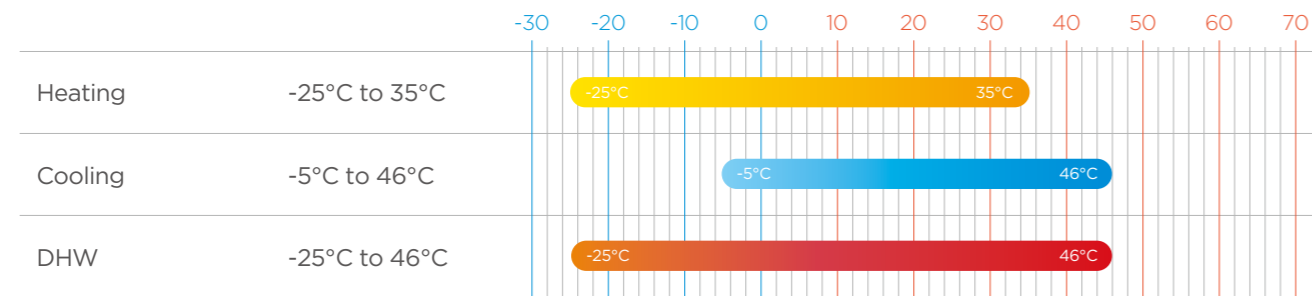

Leaving water setting temperature

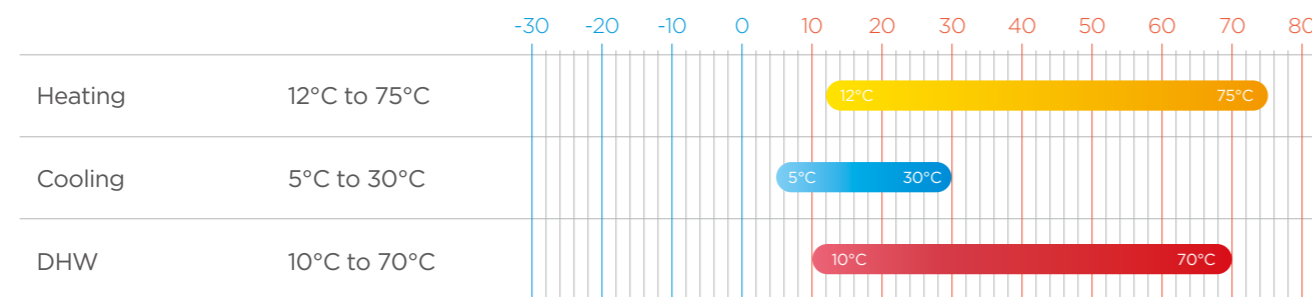

Powerful heating



55°C hot water under -25°C ambient temperature



75°C hot water under -10°C ambient temperature

R290

Naturally occurring Refrigerant

GWP=3

Lower impact on global warming

ODP=0

Neutral for the ozone layer

- Much lower GWP value to meet EU carbon neutrality
- No ozone depletion potential
- Excellent thermodynamic performance
- Great thermal efficiency for most conditions
- Reduced charge than most refrigerant in the market
- A safe bet for the long term solution

High Reliability

R290 LenTherma heat pump adopts well-known brand components and advanced manufacturing processes to ensure product reliability. It is worth mentioning that, in order to best reassure customers about the use of R290 heat pump, the electric control system adopts a hermetic design to further improve the overall reliability.

Advanced manufacturing technology

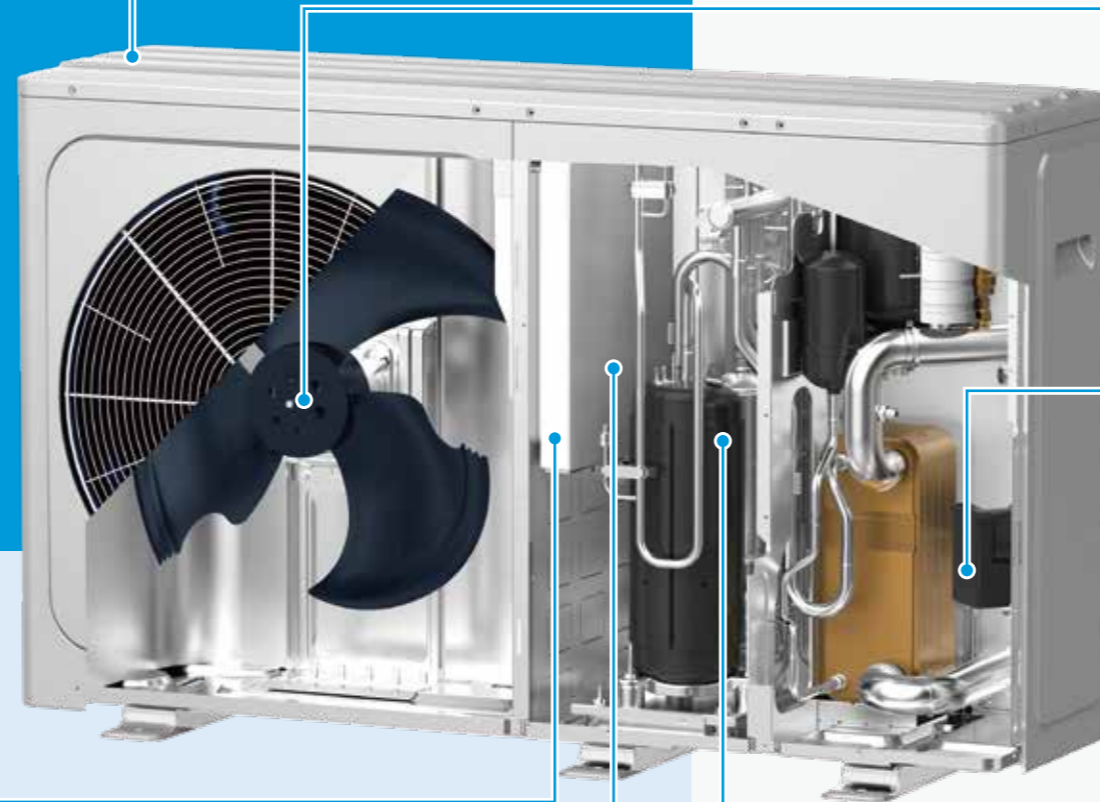

DC Inverter

All DC Inverter components

DC Inverter fan motor

- CE/CCC certification
- BLDC fan motor with stepless control
- Quiet operation
- Low power consumption
- 8 poles
- Insulation grade E

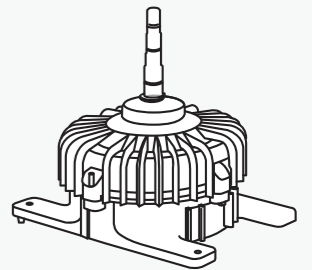

DC Inverter water pump

- CE certification
- High efficiency
- 9m pump head
- Insulation grade F
- Level of protection IPX44

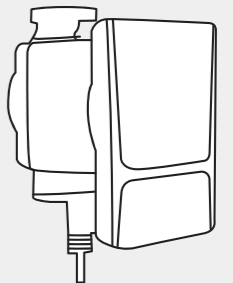

DC Inverter compressor

CE certification

Wide working frequency

- High efficiency
- Six poles
- Insulation grade E

Twin eccentric cams

- 2 balance weights
- Better balance
- Low vibration

Compact structure

- Highly robust bearings
- Highly stable moving parts

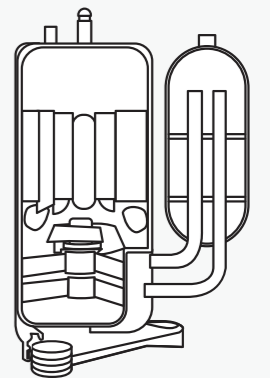

Hermetic electric control box



- Excellent sealability



- Explosion-proof design



Fuse

Relay

Varistor

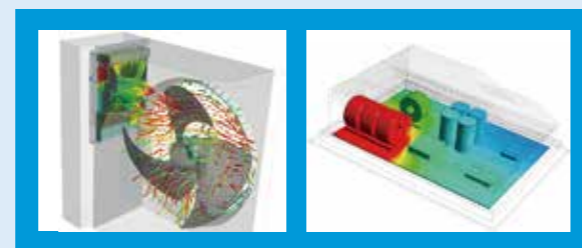

Upgrade air flow design

Thanks to the special air flow design and multiple simulations, the heat dissipation rate of electric control system has been greatly improved, which provides a strong support for heat pump to run stably in a wide ambient temperature range of -25°C to 46°C



Quiet

- Silence mode operation

Silence mode decreases the sound effectively. Level 2 is more silent than level 1.

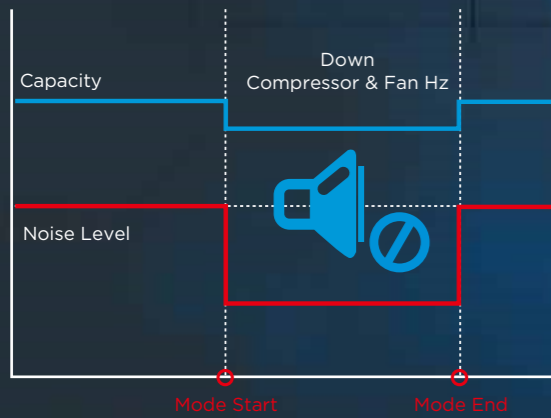

- Twin rotary compressor



- Silent mode

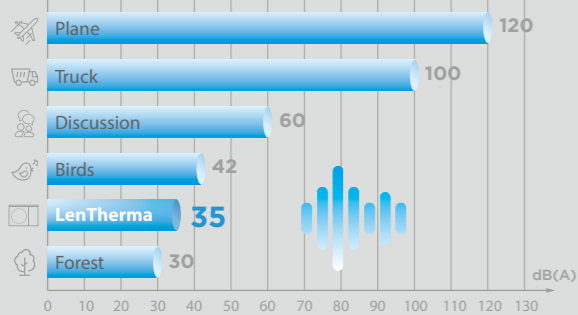

Mono 4kW model produces 35dB(A) sound pressure level at 3 meters. thanks to multiple optimization design.

Test condition:

1. Outdoor air temperature 7°C DB, 6°C WB; Water inlet 30°C , Water outlet 35°C.
2. Outdoor air temperature 35°C DB; Water inlet 23°C , Water outlet 18°C

- Optimized piping distribution

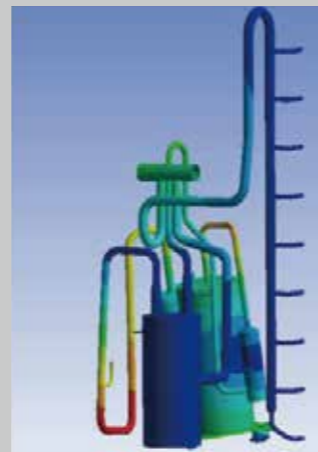

Modal analysis and harmonic response analysis help to improve the piping design for reducing noise

- Bionic fan design

Suction surface concave design

Reduce the size of wake shedding vortex
Improve the flow field on blade surface
Reduce weight and improve efficiency

Leading edge thickening design

Reduce low frequency noise Effectively improve the blade strength

Trailing edge notch design

- Change pressure distribution in the trailing edge of the blade
- Reduce the noise of blade wake vortex shedding

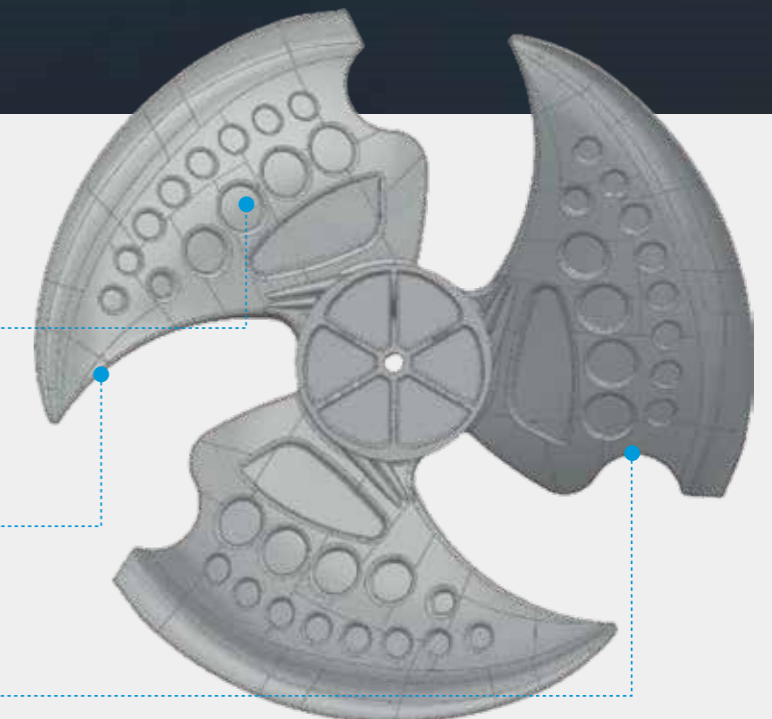

Convenient

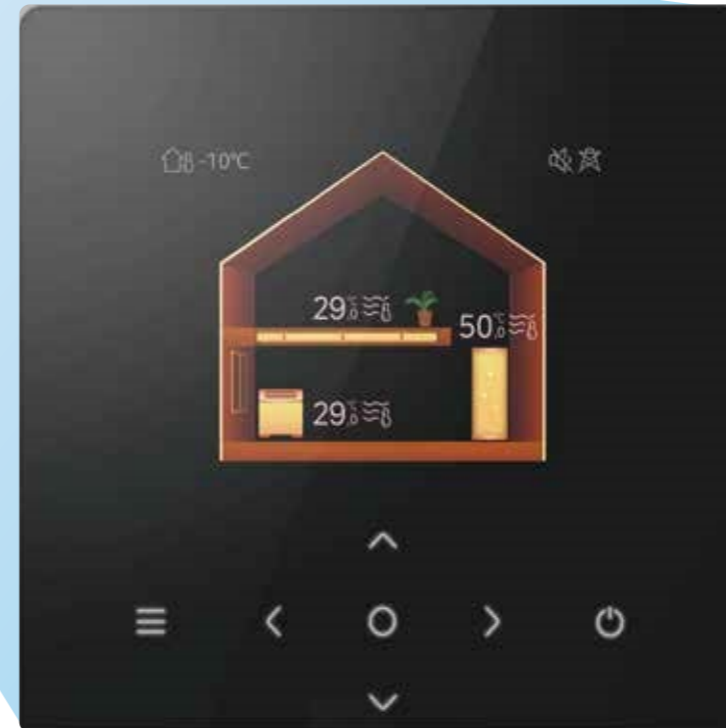

- Color screen
- Scenic and intuitive interface
- Temperature status display
- All terminals' status display
- Liquid crystal display panel
- Non-polarized wiring connection
- Touch-key design
- Built-in Wifi module
- Modbus protocol
- APP control
- Multiple languages



Daily timer



Electrical heater



Silent mode



Holiday mode



Compressor



Disinfection



Energy saving mode



Additional heat source



Water pump



Weekly timer



Defrost



Anti-freezing function



Mains electricity



Solar heating function



Smart Home APP

- 
 Easy setting
- 
 Double zones control
- 
 Monitor system status
- 
 Power consumption
- 
 Remote control
- 
 Energy saving suggestion
- 
 Schedule function

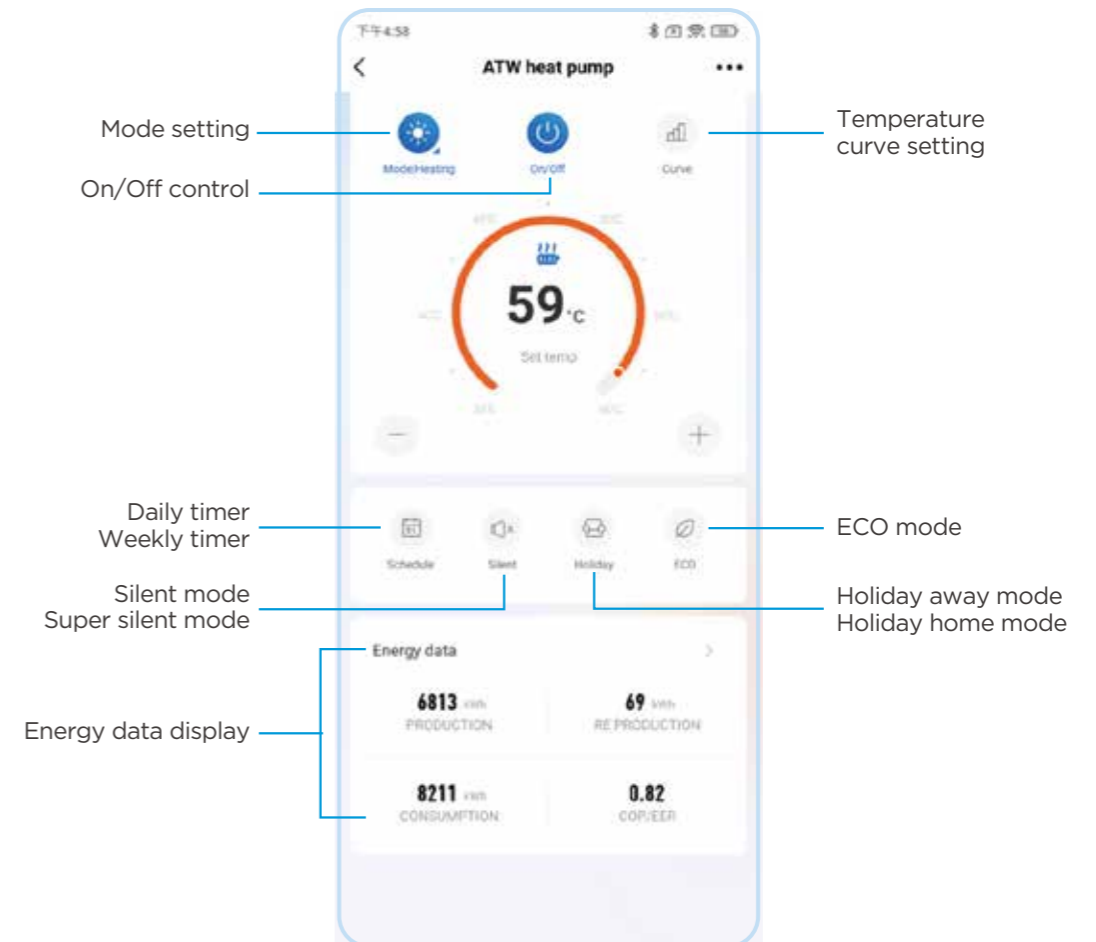

Note:
 APP interface changes from time to time as APP is updated and may change slightly vary from those in this document.

Energy Utilization and Analysis



Smart Grid

Heat pump adjusts the operation mode according to different grid signals to realize energy saving. When the electric price is low or even free, heat pump takes DHW priority. When the electric price is high, DHW-related functions are limited. When the electric price is normal, heat pump operates according to users' requirement.



Climate curves

This function aims that water temperature regulates automatically depending on the outdoor ambient temperature.

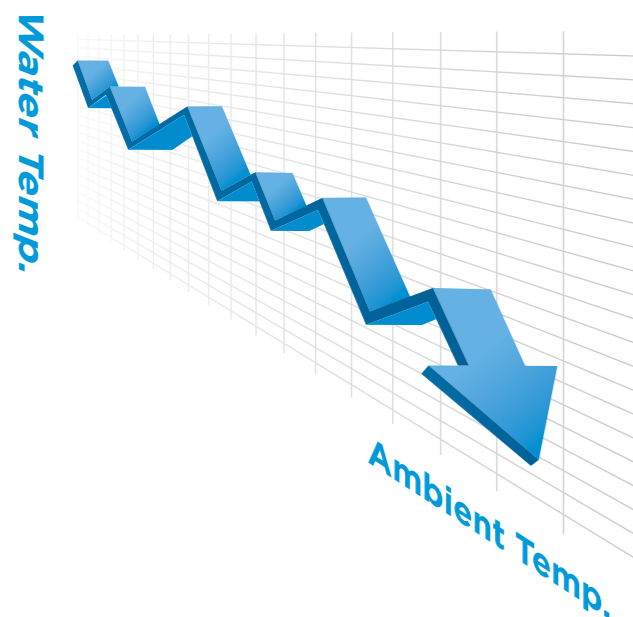

- Three types of temperature types: Standard, Custom, and ECO
- 32 standard weather temperature curves
- "Temperature offset" function to control precisely
- Customized curves in different zones and different modes

Energy and electric consumption

Energy consumption and suggestion

- LenTherma unit can be controlled through APP and energy consumption can be displayed on APP.
- Energy-saving suggestion can be displayed on APP.

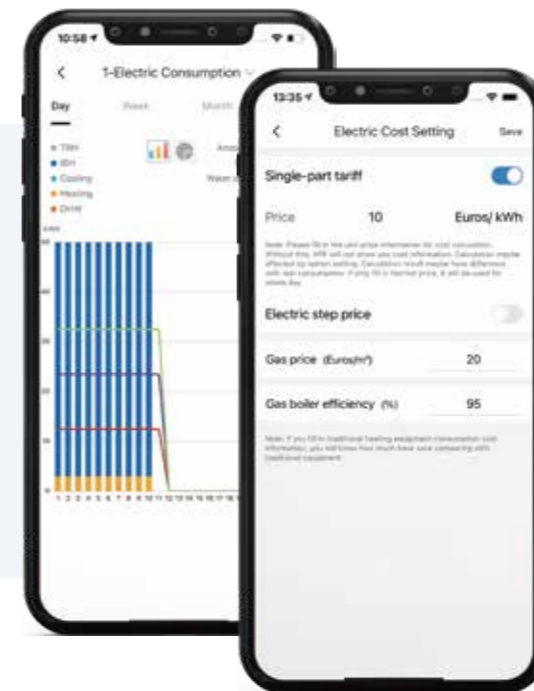

Electric consumption function

- Electric consumption and cost calculation function are available to activate for monitoring the electricity consumed.

Typical Applications

System configurations

LenTherma system can be configured to run with the electric heater either enabled or disabled and can also be used in conjunction with an auxiliary heat source such as a boiler.

The chosen configuration affects the size of heat pump that is required. Three typical configurations are described below.

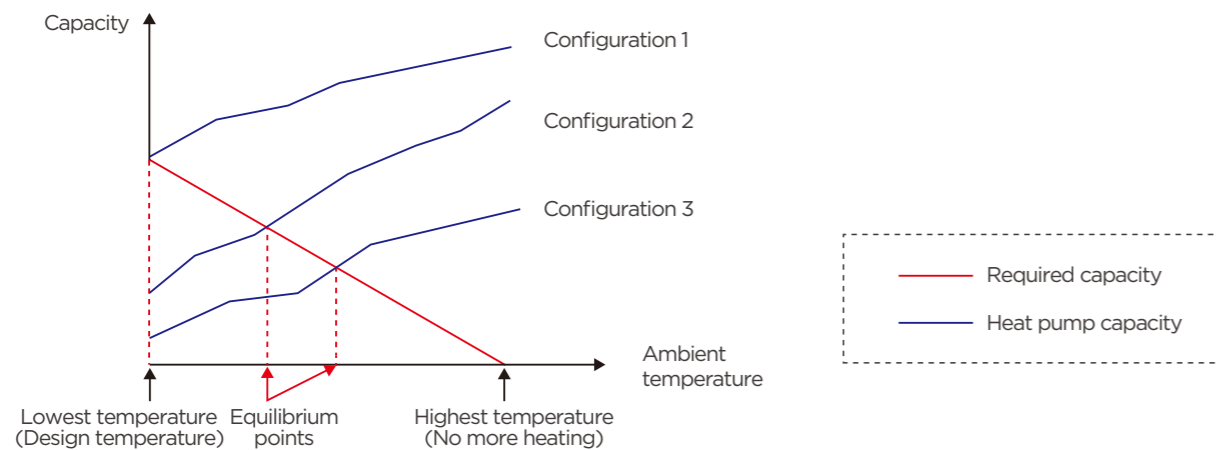

Configuration 1: Heat pump only

- The heat pump covers the required capacity and no extra heating capacity is necessary.
- Requires selection of larger capacity heat pump and implies higher initial investment.
- Ideal for new construction in projects where energy efficiency is paramount.

Configuration 2: Heat pump and backup electric heater

- Heat pump covers the required capacity until the ambient temperature drops below the point at which the heat pump is able to provide sufficient capacity. When the ambient temperature is below this equilibrium point, the backup electric heater supplies the required additional heating capacity.
- Best balance between initial investment and running costs, results in lowest lifecycle cost.
- Ideal for new construction.

Configuration 3: Heat pump with auxiliary heat source

- Heat pump covers the required capacity until the ambient temperature drops below the point at which the heat pump is able to provide sufficient capacity. When the ambient temperature is below this equilibrium point, depending on the system settings, either the auxiliary heat source supplies the required additional heating capacity or the heat pump does not run and the auxiliary heat source covers the required capacity.
- Enables selection of lower capacity heat pump.
- Ideal for refurbishments and upgrades.

Selection Procedure

Step 1 Total heat load calculation

Calculate conditioned surface area and select the heat emitters (type, quantity, water temperature and heat load)

Step 2 System configuration

Decide whether to include AHS and set AHS' s switching temperature
Decide whether backup electric heater is enabled or disabled.

Step 3 Selection

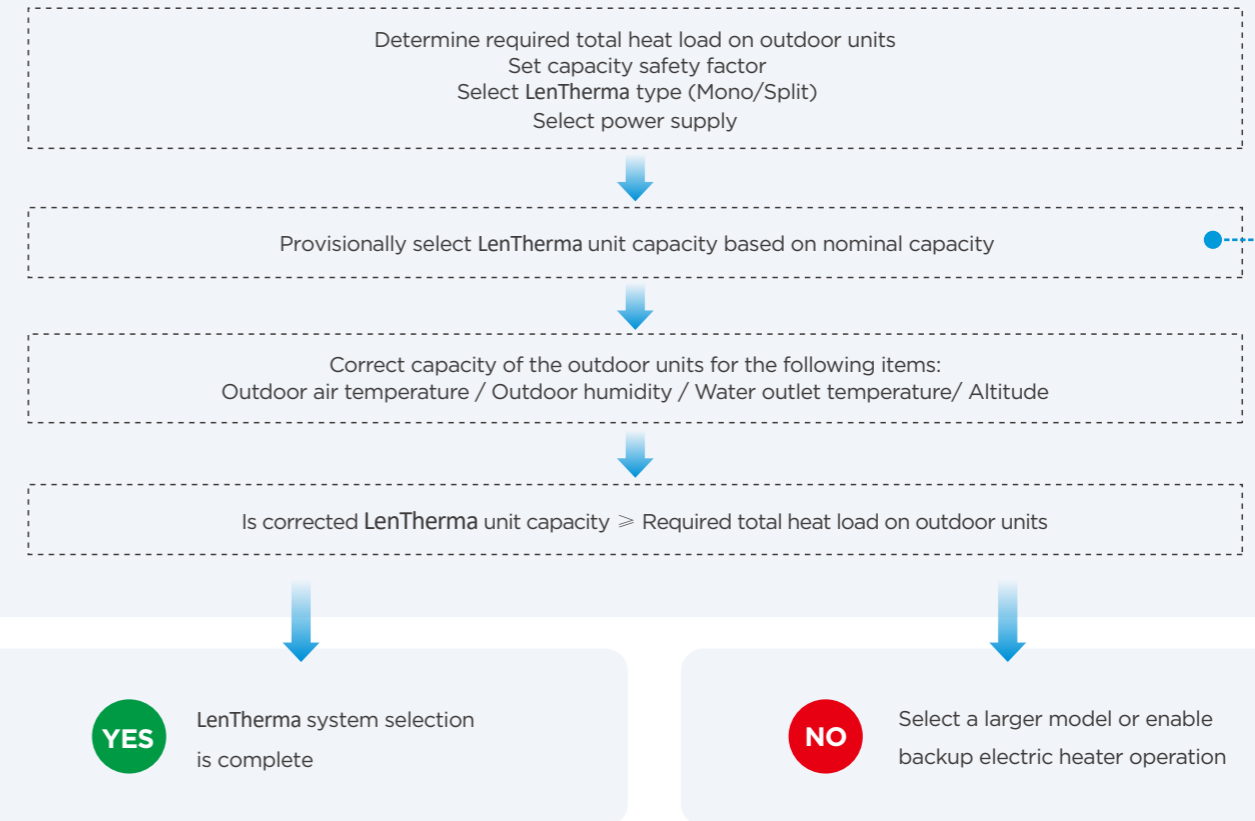

Leaving Water Temperature (LWT)

The recommended design LWT ranges for different types of heat emitter are:

For floor heating: 30°C to 35°C

For fan coil units: 40°C to 45°C

For low temperature radiators: 40°C to 55°C

Application Scenarios

Practical applications are various, including but not limited to the following applications. The application examples given below are for illustration only.

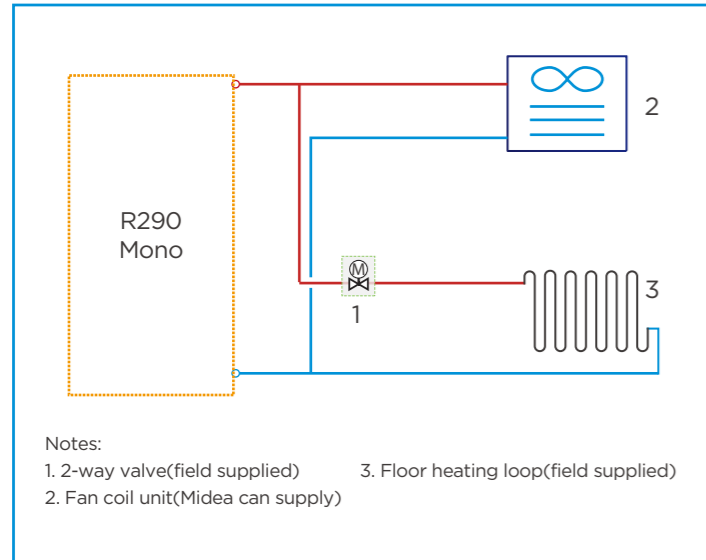

Heating and cooling

Floor heating loops is used for space heating and fan coil unit is used for space cooling. 2-way valve is used to prevent water from entering floor heating loops then result in condensation during cooling.

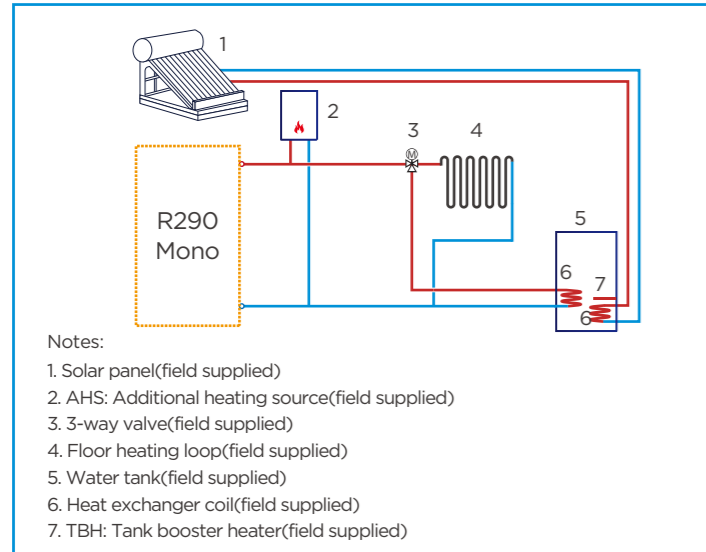

Heating, DHW and hybrid heat source

Backup electric heater(optional) or AHS provide additional heating to raise the leaving water temperature. TBH and solar system provide additional heating to raise the domestic hot water temperature. 3-way valve is used to switch between heating mode and DHW mode.

Double zones control

Double zones control is only available for heating mode. It can control different areas to reach different temperature to meet various needs. Mixing station is used to adjust appropriate water temperature for floor heating loops using.

1. Using wired controller only

Wired controller sets the mode, temperature and on/off. Zone 1 is controlled based on the leaving water temperature. Zone 2 is controlled based on the leaving water temperature or room temperature.

2. Using wired controller and thermostat

Wired controller sets the mode and water temperature. Both Zone 1 and Zone 2 can be controlled by thermostat. Zone1 is controlled by "HT" terminal, Zone 2 is controlled by "CL" terminal.

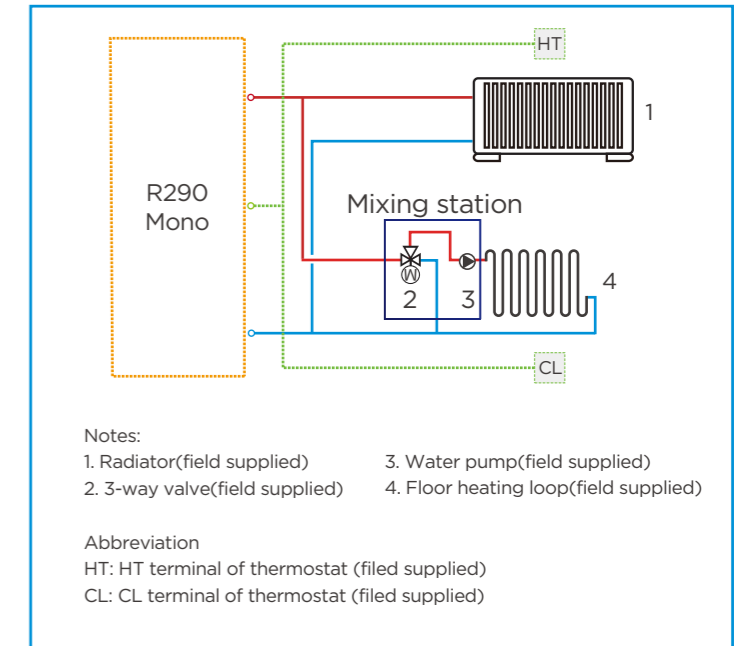

Mono Cascade system

Cascade system design is perfect when an extension of capacity becomes required as the building demand evolves. Maximum 6 units can be controlled in group with one controller. Balance tank temperature control makes water temperature more accurate.

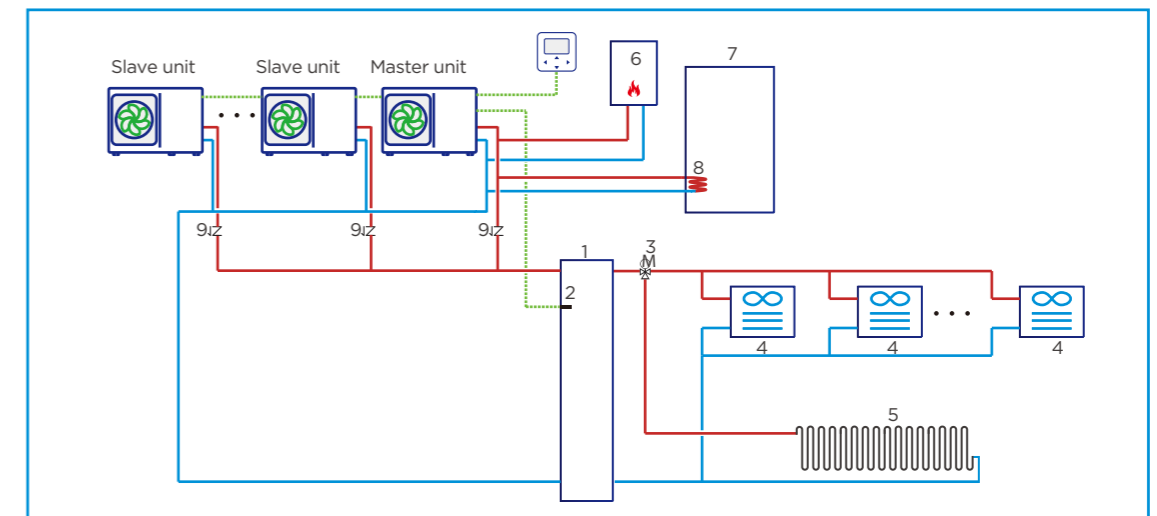

Notes:

- 1. Balance tank(field supplied)
- 2. Balance tank temperature sensor(Midea can supply)
- 3. 3-way valve(field supplied)
- 4. Fan coil unit(Midea can supply)
- 5. Floor heating loop(field supplied)

- 6.AHS: Additional heating source(field supplied)
- 7.Water tank(field supplied)
- 8.Heat exchanger coil(field supplied)
- 9.Single way valve (field supplied)

Specifications



Model		LV-HPM04-I7T	LV-HPM06-I7T	LV-HPM08-I7T	LV-HPM10-I7T	LV-HPM12-I7T	LV-HPM14-I7T	LV-HPM16-I7T	LV-HPM12-I7M	LV-HPM14-I7M	LV-HPM16-I7M	
Power supply		220-240V-50Hz	220-240V-50Hz	220-240V-50Hz	220-240V-50Hz	220-240V-50Hz	220-240V-50Hz	220-240V-50Hz	380-415V-3N-50Hz	380-415V-3N-50Hz	380-415V-3N-50Hz	
Heating A7W35	Capacity	W	4500	6200	8400	10000	12000	14000	15000	12000	14000	15000
	Rated input	W	874	1265	1680	2128	2500	3111	3409	2500	3111	3409
	COP		5.15	4.90	5.00	4.70	4.80	4.50	4.40	4.80	4.50	4.40
Heating A7W45	Capacity	W	4500	6400	8200	10000	12000	14000	15000	12000	14000	15000
	Rated input	W	1111	1684	2130	2740	3243	4000	4478	3243	4000	4478
	COP		4.05	3.80	3.85	3.65	3.70	3.50	3.35	3.70	3.50	3.35
Heating A7W55	Capacity	W	4600	6200	7800	9500	12000	14000	15000	12000	14000	15000
	Rated input	W	1438	2000	2438	3115	3871	4667	5263	3871	4667	5263
	COP		3.20	3.10	3.20	3.05	3.10	3.00	2.85	3.10	3.00	2.85
Heating A2W35	Capacity	W	4400	5600	7100	8200	9100	10800	12800	9100	10800	12800
	Rated input	W	1073	1436	1844	2247	2395	3086	4000	2395	3086	4000
	COP		4.10	3.90	3.85	3.65	3.80	3.50	3.20	3.80	3.50	3.20
Heating A-7W35	Capacity	W	4500	5900	7000	8000	10000	11500	12700	10000	11500	12700
	Rated input	W	1452	2000	2333	2807	3571	4259	5080	3571	4259	5080
	COP		3.10	2.95	3.00	2.85	2.80	2.70	2.50	2.80	2.70	2.50
Cooling A35W18	Capacity	W	4500	6500	8300	10000	12000	14000	16000	12000	14000	16000
	Rated input	W	818	1275	1612	2105	2667	3333	4103	2667	3333	4103
	EER		5.50	5.10	5.15	4.75	4.50	4.20	3.90	4.50	4.20	3.90
Cooling A35W7	Capacity	W	4700	6800	7500	8900	11500	12700	14000	11500	12700	14000
	Rated input	W	1288	2194	2174	2738	3770	4379	5091	3770	4379	5091
	EER		3.65	3.10	3.45	3.25	3.05	2.90	2.75	3.05	2.90	2.75
SCOP	Average climate, W35		A+++									
	Average climate, W55		A++									
ErP sound power level	dB	56	58	60	61	65	65	69	65	65	69	
Refrigerant	Type(GWP)	R290(3)										
	Charged volume	g	700		1100		1250					
Unit dimension (W×H×D)	mm	1299×717×426				1385×865×523						
Packing dimension (W×H×D)	mm	1375×885×475				1465×1035×560						
Net weight	kg	90		117		135		137				
Gross weight	kg	110		139		157		159				
Water side Connection dimension		G1" BSP			G1 1/4" BSP							
Outdoor air temperature range	Cooling	°C	-5 ~ 46									
	Heating	°C	-25 ~ 35									
	DHW	°C	-25 ~ 46									
Water setting temperature range	Cooling	°C	5 ~ 30									
	Heating	°C	12 ~ 75									
	DHW	°C	10 ~ 70									

Note:

The above data test reference standard EN14511; EN14825; EN50564; EN 12102; (EU) No:811

